

**INSTALLATION OPTION
J-HOOKS ENGAGED TO TENDONS**

- STEP 1: MAKE 2 LOOPS IN THE TENDON.
- STEP 2: PULL LOOP 1 PARTIALLY THROUGH LOOP 2.
- STEP 3: INSERT THE J-HOOK ANCHOR THROUGH LOOP 1 AND DRIVE J-HOOK INTO THE GROUND UNTIL THE TOP OF THE HOOK IS LEVEL WITH THE TOP OF THE CELLTEK SECTION.
- STEP 4: PULL BOTH ENDS OF TENDON TO CLOSE THE LOOP AND DRIVE J-HOOK UNTIL THE TOP OF IT IS FLUSH WITH GROUND SURFACE.

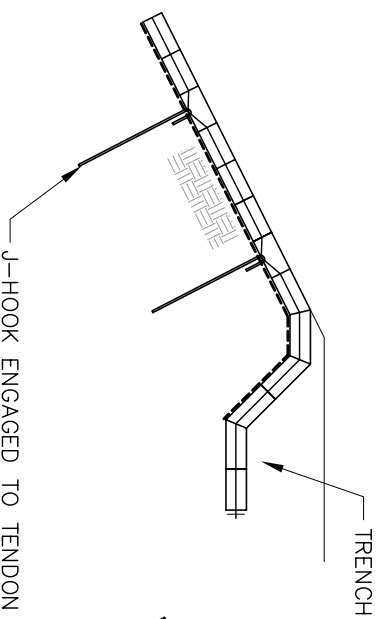

ANCHORING OPTIONS

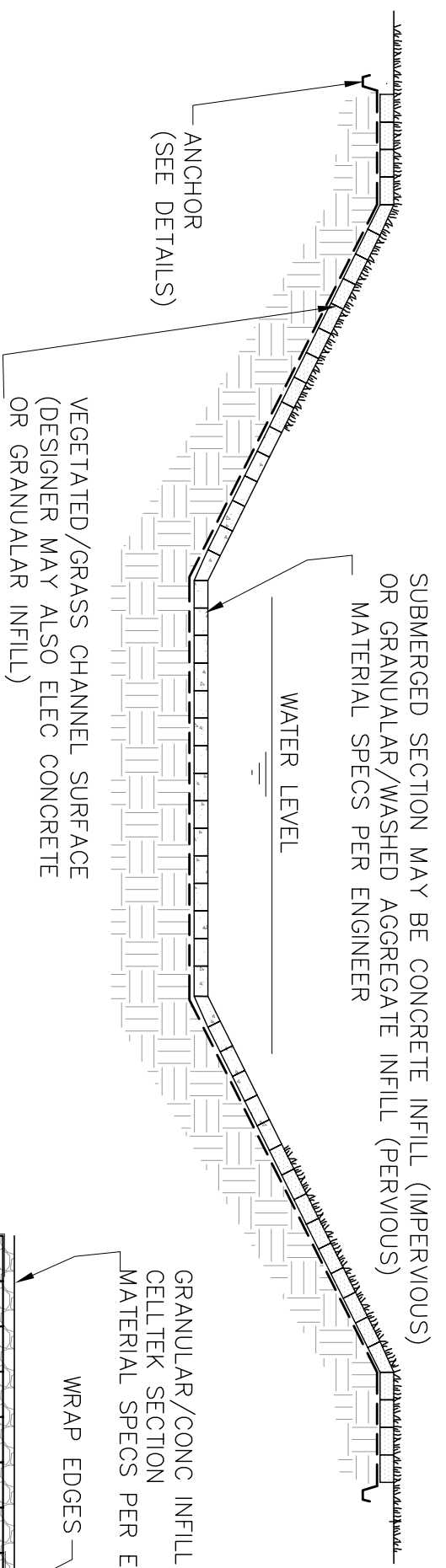
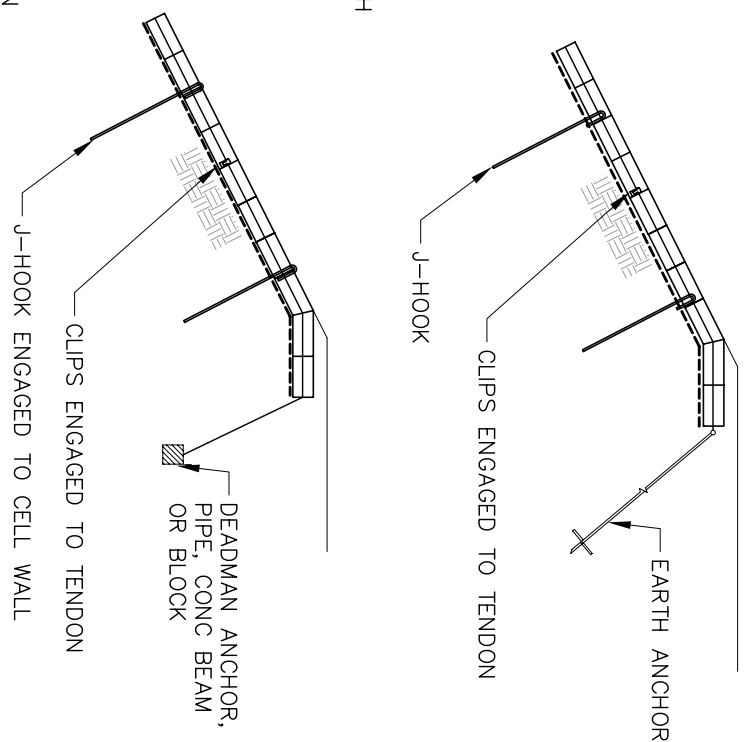

**INSTALLATION OPTION
J-HOOK ENGAGED TO CELLS**

- TENDONS PRE-THREADED THROUGH INDIVIDUAL CELLTEK SECTION PRIOR TO EXPANDING SYSTEM
- POSITION STAKE NEXT TO CELL WALL.
- DRIVE STAKE INTO THE GROUND UNTIL FLUSH WITH TOP OD CELL WALL.

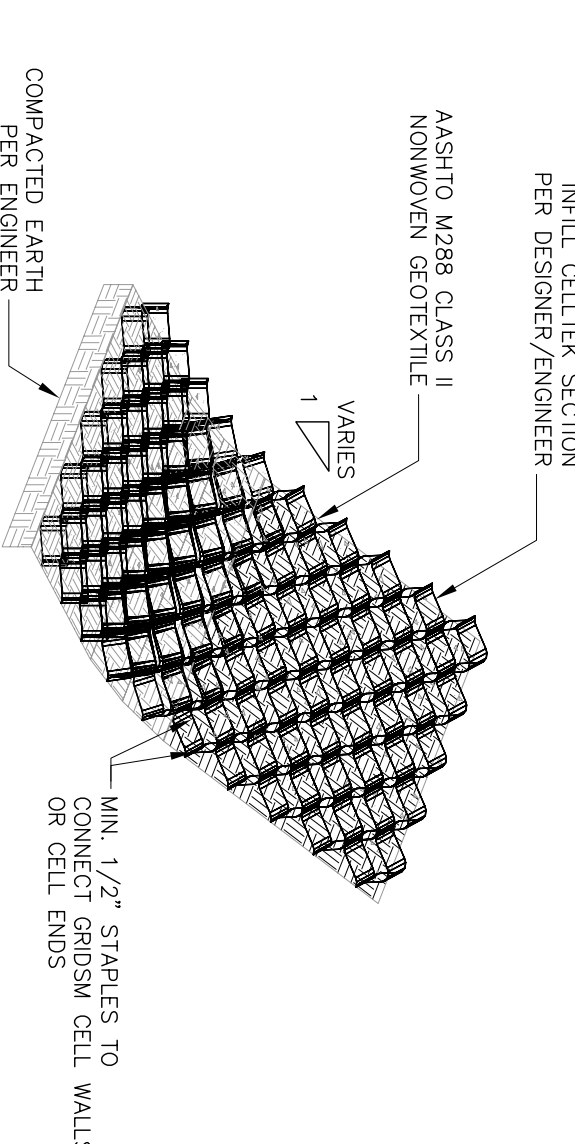
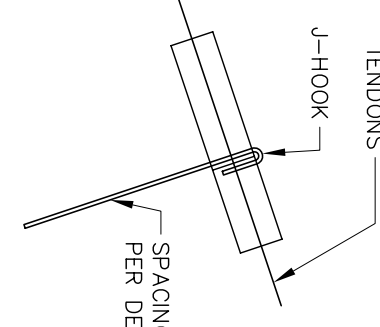

DRAWN BY:	as	
CHECKED BY:	AS	4/15/08
		SHEET 1



TOLL FREE 888-851-0051
WWW.CELLTEKDIRECT.COM



CHANNEL PROTECTION